

Solar and Electric Water Heaters

Chromagen is a leading international manufacturer of solar and electric water heaters, combining the most advanced technology and traditional heating methods. Our products incorporate state-of-the-art engineering, rugged construction and select materials, resulting in efficient and durable products.

Chromagen's wide selection of tanks are environmentally friendly and energy efficient. Available in a range of sizes from 30 to 300 liters. The horizontal or vertical orientation options enable flexible installation to fit changing customer needs.

Double Jacket Solar Water Tank

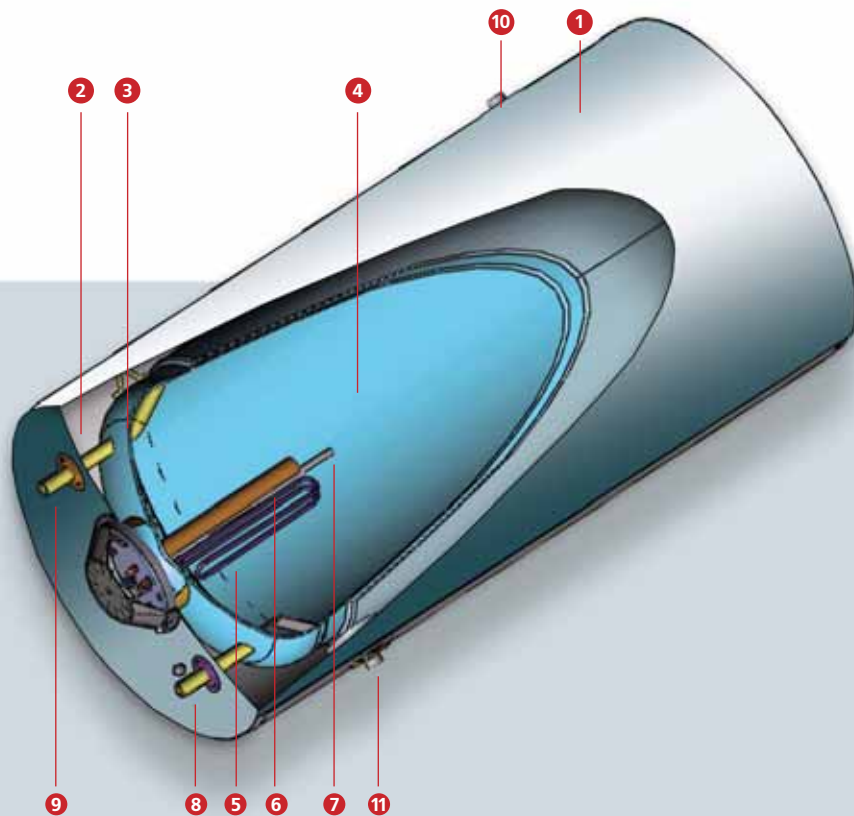

- 1 External coating**
Stainless steel or white polyester coating provides extreme durability and an attractive finish.
- 2 Insulation**
A 30mm thick polyurethane insulation layer ensures optimal insulation and retention of heat.
- 3 Storage tank**
Constructed with a 3mm thick steel, automatically welded ensuring precision and permitting a working pressure of 8 bar.
- 4 Enamel coating**
An internal glass-enamel layer protects against corrosion.
- 5 Electric element**
Energy-efficient electric element with rapid heating time enables the provision of hot water 24 hours a day, 365 days a year.
- 6 Sacrificial anode**
Provides anti-corrosion protection.
- 7 Thermostat**
A built in thermostat ensures that water inside the tank does not exceed a preset temperature, while using the electric element.
- 8 Cold water inlet**
- 9 Hot water to user**
- 10 Heat exchanger inlet**
- 11 Heat exchanger outlet**

Technical Specifications

Solar Tanks

Capacity (l)	A (mm)	B (mm)	C (mm)	Weight (kg.)	Electric Element (watt)
80	650	590	560	40	2500w
120	850	790	560	46	2500w
150	1010	950	560	53	2500w
170	1095	1055	560	58	2500w
200	1270	1210	560	65	2500w
300	1420	1360	650	91	2500w, 3000w

Electric Tanks

Capacity (l)	A (mm)	B (mm)	C (mm)	Weight (kg.)	Electric Element (watt)
30	670	560	360	23	2500w
45	885	780	360	29	2500w
60	740	675	477	31	2500w
80	905	845	477	40	2500w
120	850	790	585	46	2500w
120	1245	1185	477	50	2500w
150	1010	950	585	53	2500w
200	1270	1210	585	65	2500w

Solar and Electric Tanks with Heat-Exchanger

Capacity (l)	A (mm)	B (mm)	C (mm)	Weight (kg.)	Electric Element (watt)
120	1245	1185	477	74	2500w
150	1010	950	585	75	2500w
170	1115	1055	585	83	2500w
200	1270	1210	585	93	2500w
300	1420	1360	690	133	2500w, 3000w

- Available horizontal or vertical. All tanks are tested at a pressure of 15 bars, with a permitted working pressure of up to 8 Bars.
- Due to on-going developments specifications are subject to change without notice.

